

Volume Potentiometer with On/Off Switch Low-profile TP76N00B Series

Innovative rotational SW design serves to achieve breakthrough
in downsizing from conventional 10mm to 7mm in depth !

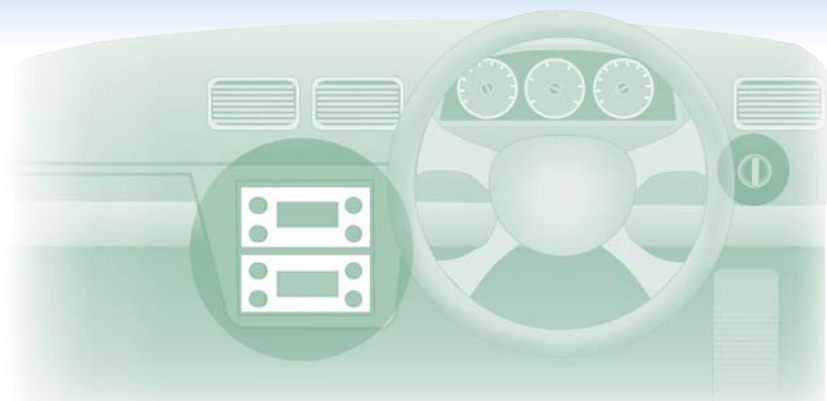

The series will certainly meet a growing trend toward multi-function and optimize customers----- for 2-way radios, communication devices, measuring instruments and audio/visual equipment.

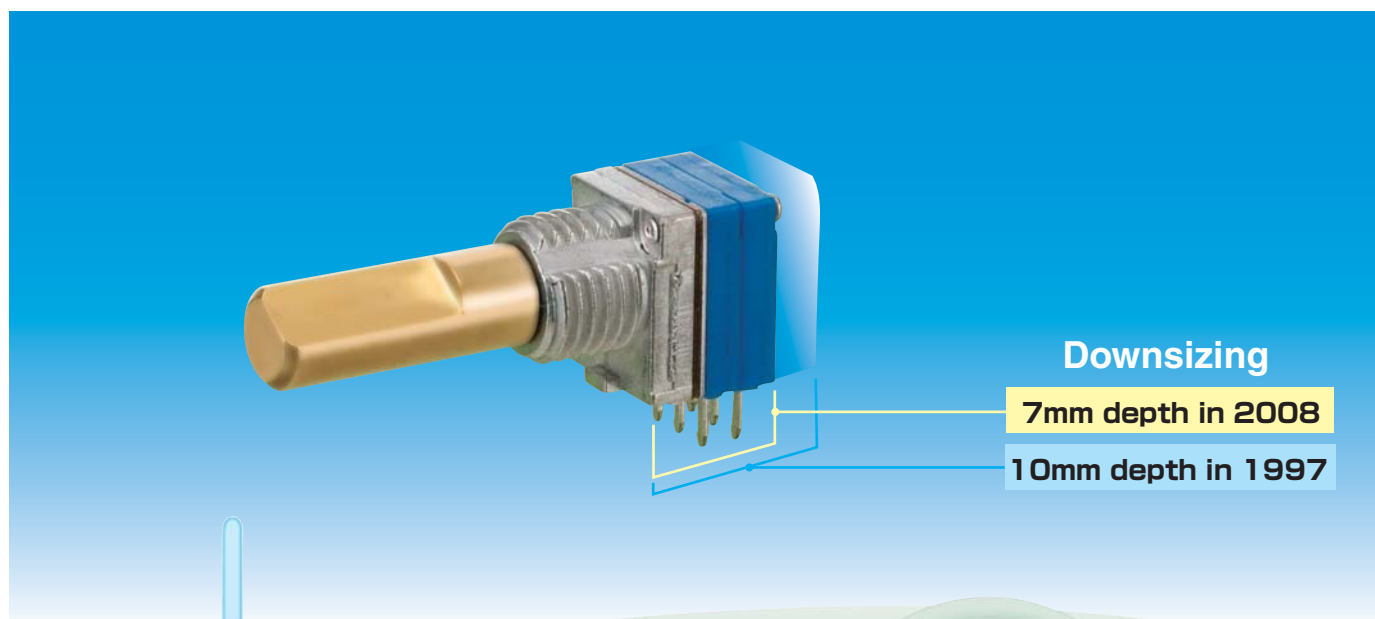
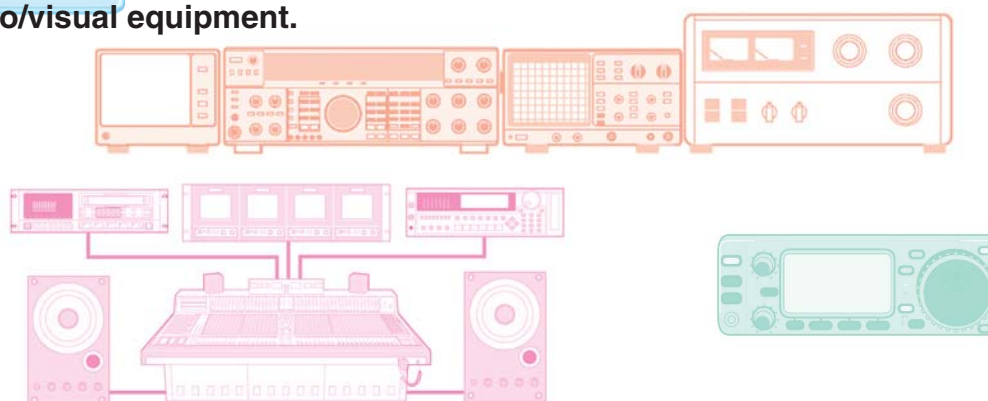

Volume Potentiometer with On/Off Switch

TOCOS®

Low-profile TP76N00B Series

TP76N00B Series



Single shaft, single unit
(Volume pot. + Low profile SW)

There is a need for more multi-functionality and more downsizing in today's product design.

The world's smallest volume potentiometer with on/off (7mm in depth), TOCOS TP76N00B series optimize customers.

■ Features

- Small size
- Consistent performance
- Long life
- Flexible to custom design
- Excellent linearity

Specifications

Total resistance	B: 2k to 1MΩ A: 5k to 500kΩ
End resistance	50Ω Max.
Noise	100mV Max.(JIS method-A)
Insulation resistance	100MΩ Min. at DC 250V.
Dielectric strength	1 minute Min. at AC 300V.
Rotational angle (Mechanical)	300±5°
Rotational torque	2.0 to 24.5mN · m(20 to 250gf · cm)
Shaft stopper strength	0.3N · m min. (3kgf · cm min.)
Strength	Shaft pull/push 98.1N (10kgf) Min.
Shaft wobble and bend	Thrust: 0.5mm max. Radial: 0.5×(Shaft/30) mm Max.
Rotational life	15,000 cycles
Switch configuration	S.P.S.T.
Switch rating	DC10V 0.1A
Switch angle	50° max.
Switch torque	78.4mN · m(800gf · cm) Max.
Switch contact resistance	200mΩ Max.
Switch life	10,000 cycles

Appearance drawing

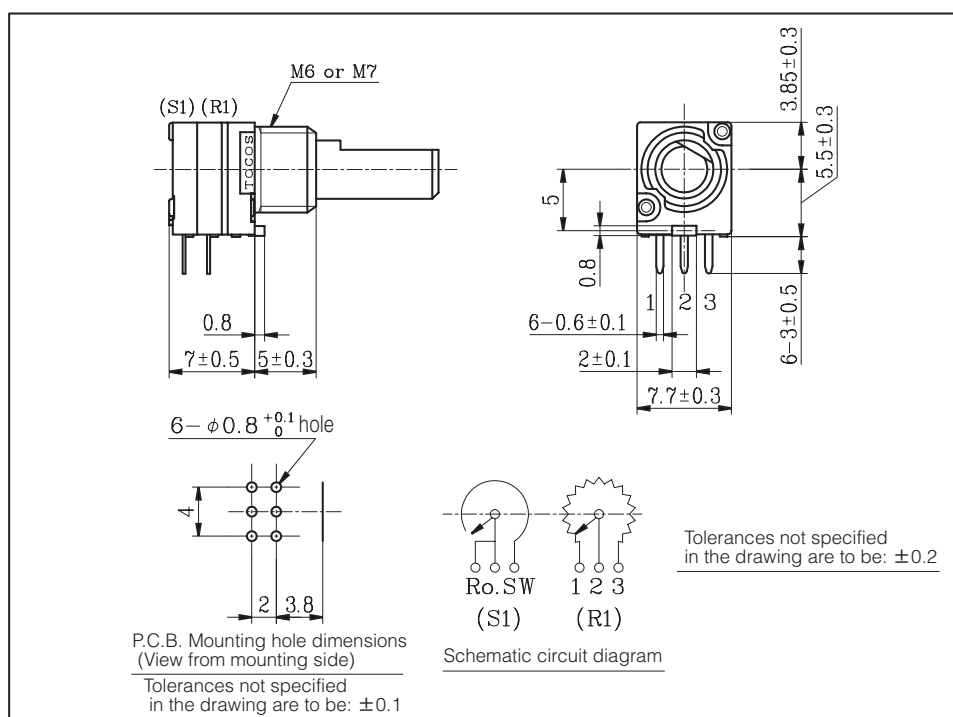

ISO9000, ISO14000 Certified



Tokyo Cosmos Electric Co., Ltd.

2-268 Sobudai, Zama Kanagawa 228-8510 Japan
TEL 81-46-253-2115 FAX 81-46-253-3640

Web: www.tocos-j.co.jp

E-mail: int@tocos-j.co.jp