

スライド形ポジションセンサ SLIDE POSITION SENSORS

RoHS 指令対応 RoHS compliant

仕様 電気的性能

- 公称全抵抗値範囲 2K, 5K
- 全抵抗値許容差 ±30%
- 直線性 ±0.5%

Specifications Electrical

- Nominal total resistance range 2K Ω to 200K Ω
- Resistance tolerance ±30%
- Linearity ±0.5%

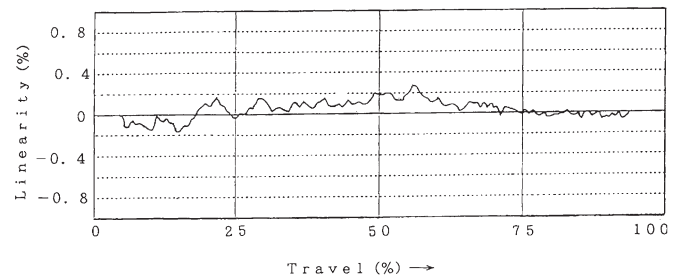
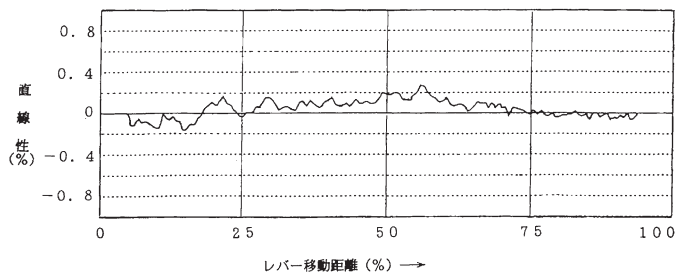

- 定格電力 0.05W
- 絶縁抵抗 DC250V 100M Ω 以上
- 耐電圧 AC300V 1分間

- Power rating 0.05W
- Insulation resistance 100M Ω Min. at DC250V
- Dielectric strength 1 minute at AC300V

機械的性能

- レバーの移動距離 22mm, 31.5mm
- 作動力 0.25N以下 (25gf以下)
- レバーの移動止め 強度9.81N (1Kgf)

Mechanical

- Travel 22mm, 31.5mm
- Operating force 0.25N Max. (25gf Max.)
- Lever stopper strength 9.81N(1Kgf)

環境性能

- しゅう動寿命 70,000サイクル
- 使用温度範囲 -10~+70°C

Environmental

- Sliding life 70,000 cycles
- Operating temperature range -10 to +70°C

スライド形ポジションセンサ SLIDE POSITION SENSORS

(Unit : mm)

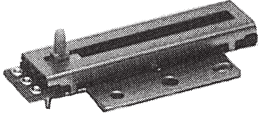
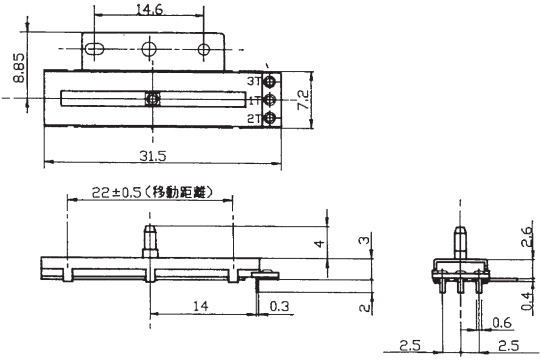
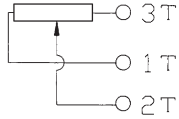
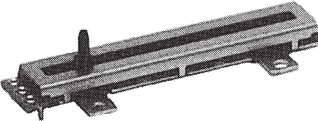
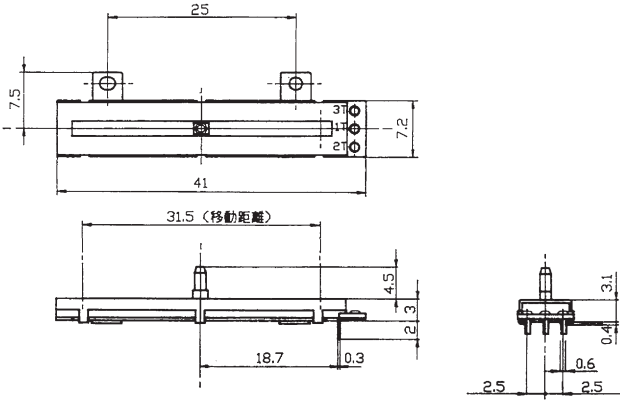
<p>製品名 Model</p>	<p>外形図 Outline Drawing</p>	<p>特長・個別仕様 Features/Individual Specifications</p>
<p>単連ポジションセンサー Single unit, Position sensor SVQL202N</p> 		<p>20mm stroke Single unit ±0.5% linearity</p> 
<p>単連ポジションセンサー Single unit, Position sensor SVQL302N</p> 		<p>30mm stroke Single unit ±0.5% linearity</p> 